

## Description

The GC11N70 uses advanced super junction technology and design to provide excellent  $R_{DS(ON)}$  and low gate charge. This device is suitable for industry AC-DC SMPS requirement of PFC, AC/DC power conversion, and other industrial power application.

## General Features

- New technology for high voltage device
- Low on-resistance and low conduction losses
- Small Package
- Ultra Low Gate Charge cause lower driving requirement
- 100% Avalanche Tested
- RoHS Compliant

## Application

- Power Factor Correction (PFC)
- Switched Mode Power Supply (SMPS)
- Uninterruptible Power Supply (UPS)

$V_{DS}$	$R_{DS(ON)}$ @ 10V (max)	$I_D$
700V	395mΩ	11A

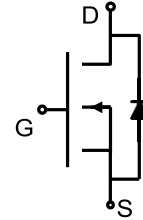

Schematic Diagram

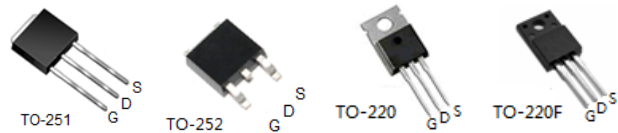

## Ordering Information

Part Number	Marking	Case	Packaging
GC11N70J	GC11N70	TO-251	72pcs/Tube
GC11N70K	GC11N70	TO-252	2500pcs/Reel
GC11N70T	GC11N70	TO-220	50pcs/Tube
GC11N70F	GC11N70	TO-220F	50pcs/Tube

## Absolute Maximum Ratings ( $T_C=25^\circ\text{C}$ unless otherwise noted)

Parameter	Symbol	Value		Unit
		TO-251,TO-252 TO-220	TO-220F	
Drain-Source Voltage	$V_{DS}$	700		V
Gate-Source Voltage	$V_{GS}$	±30		V
Drain Current-Continuous ( $T_C=25^\circ\text{C}$ )	$I_D$	11		A
Drain Current-Continuous ( $T_C=100^\circ\text{C}$ )	$I_D$	6.6		A
Drain Current-Pulsed (Note 1)	$I_{DM}$	33		A
Single Pulse Avalanche Energy (Note 2)	$E_{AS}$	215		mJ
Repetitive Avalanche Energy (Note 1)	$E_{AR}$	0.32		mJ
Avalanche Current (Note 1)	$I_{AR}$	1.8		A
Maximum Power Dissipation ( $T_C=25^\circ\text{C}$ )	$P_D$	83	31	W
MOSFET dv/dt ruggedness, $V_{DS} = 0 \dots 480\text{V}$	dv/dt	50		V/ns
Reverse diode dv/dt, $V_{DS} = 0 \dots 480\text{V}$ , $I_{SD} \leq I_D$	dv/dt	15		V/μs
Operating Junction and Storage Temperature Range	$T_J, T_{STG}$	-55 To 150		$^\circ\text{C}$

## Thermal Characteristic

Parameter	Symbol	Value		Unit
		TO-251,TO-252 TO-220	TO-220F	
Thermal Resistance,Junction-to-Case	$R_{thJC}$	1.5	4	°C/W
Thermal Resistance,Junction-to-Ambient (Note 2)	$R_{thJA}$	62	80	°C/W

## Electrical Characteristics ( $T_A=25^{\circ}C$ unless otherwise noted)

Parameter	Symbol	Condition	Min	Typ	Max	Unit
<b>On/ Off Characteristics</b>						
Drain-Source Breakdown Voltage	$BV_{DSS}$	$V_{GS}=0V, I_D=250\mu A$	700	-	-	V
Zero Gate Voltage Drain Current ( $T_C=25^{\circ}C$ )	$I_{DSS}$	$V_{DS}=700V, V_{GS}=0V$	-	-	1	$\mu A$
Zero Gate Voltage Drain Current ( $T_C=125^{\circ}C$ )	$I_{DSS}$	$V_{DS}=700V, V_{GS}=0V$	-	-	100	$\mu A$
Gate-Body Leakage Current	$I_{GSS}$	$V_{GS}=\pm 30V, V_{DS}=0V$	-	-	$\pm 100$	nA
<b>On Characteristics (Note 3)</b>						
Gate Threshold Voltage	$V_{GS(th)}$	$V_{DS}=V_{GS}, I_D=250\mu A$	2.5	-	4.5	V
Drain-Source On-State Resistance	$R_{DS(ON)}$	$V_{GS}=10V, I_D=5.5A$	-	-	395	m $\Omega$
Gate resistance	$R_G$	f = 1.0MHz open drain	-	18	-	$\Omega$
<b>Dynamic Characteristics (Note4)</b>						
Input Capacitance	$C_{iss}$	$V_{DS}=100V, V_{GS}=0$ $V, F=1.0MHz$	-	871	-	PF
Output Capacitance	$C_{oss}$		-	37	-	PF
Reverse Transfer Capacitance	$C_{rss}$		-	5	-	PF
<b>Switching Characteristics (Note 4)</b>						
Turn-on Delay Time	$t_{d(on)}$	$V_{DD}=400V, I_D=11A$ $V_{GS}=10V, R_{GEN}=25\Omega$	-	70	-	ns
Turn-on Rise Time	$t_r$		-	70	-	ns
Turn-Off Delay Time	$t_{d(off)}$		-	145	-	ns
Turn-Off Fall Time	$t_f$		-	59	-	ns
Total Gate Charge	$Q_g$	$V_{DD}=520V, I_D=11A, V_{GS}=10V$	-	22	-	nC
Gate-Source Charge	$Q_{gs}$		-	4	-	nC
Gate-Drain Charge	$Q_{gd}$		-	8	-	nC
<b>Drain-Source Diode Characteristics</b>						
Continuous Body Diode Current	$I_S$	$T_C=25^{\circ}C$	-	-	11	A
Pulsed Diode Forward Current	$I_{SM}$	$T_C=25^{\circ}C$	-	-	33	A
Diode Forward Voltage	$V_{SD}$	$T_J=25^{\circ}C,$ $I_{SD}=11A, V_{GS}=0V$	-	-	1.2	V
Reverse Recovery Time	$t_{rr}$	$V_R=400V, I_F=I_S,$ $di_F/dt = 100A/\mu s$	-	377	-	ns
Reverse Recovery Charge	$Q_{rr}$		-	3.4	-	$\mu C$
Peak Reverse Recovery Current	$I_{rrm}$		-	17.8	-	A

## Notes:

1. Repetitive Rating: Pulse width limited by maximum junction temperature.
2.  $I_{AS} = 1.8A, V_{DD} = 50V, R_G = 25\Omega, \text{Starting } T_J = 25^{\circ}C$
3. Pulse Test: Pulse Width  $\leq 300\mu s, \text{Duty Cycle } \leq 1\% .$
4. Guaranteed by design, not subject to production

## Typical Electrical And Thermal Characteristics

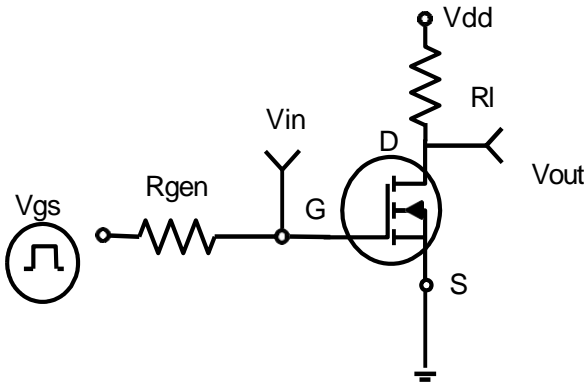

**Figure 1. Switching Test Circuit**

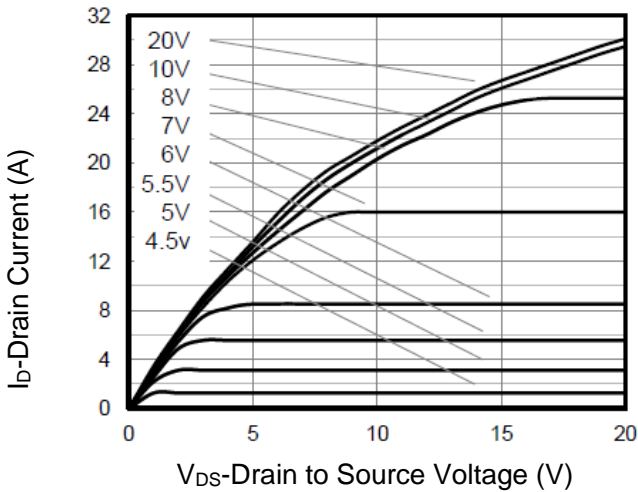

**Figure 3. Output Characteristics**

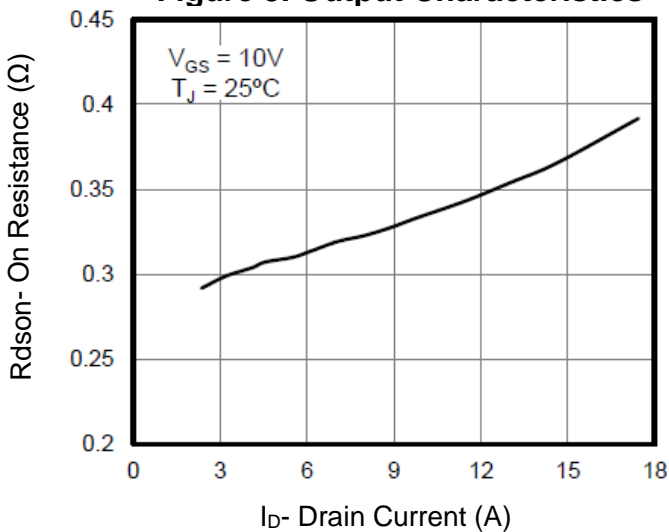

**Figure 5. On Resistance vs. Drain Current**

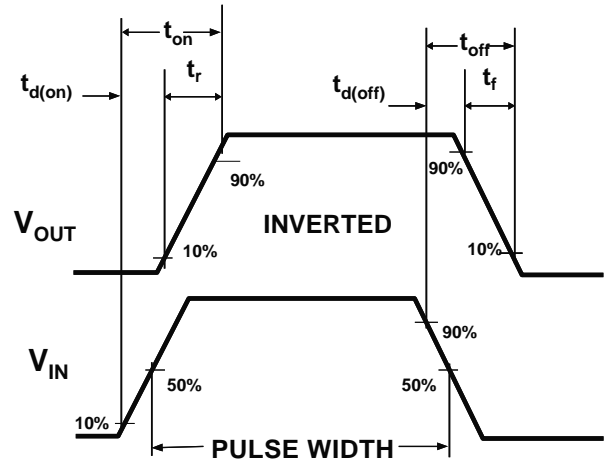

**Figure 2. Switching Waveforms**

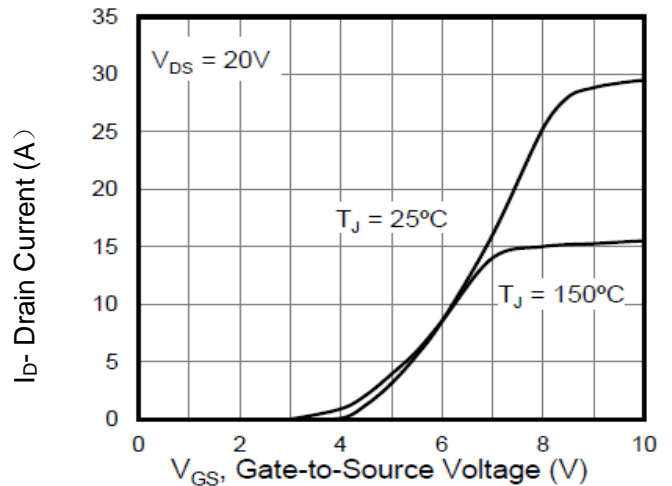

**Figure 4. Transfer Characteristics**

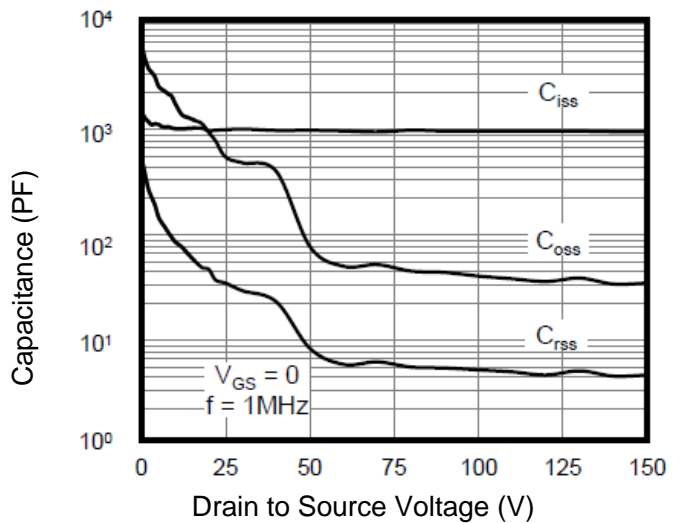

**Figure 6. Capacitance**

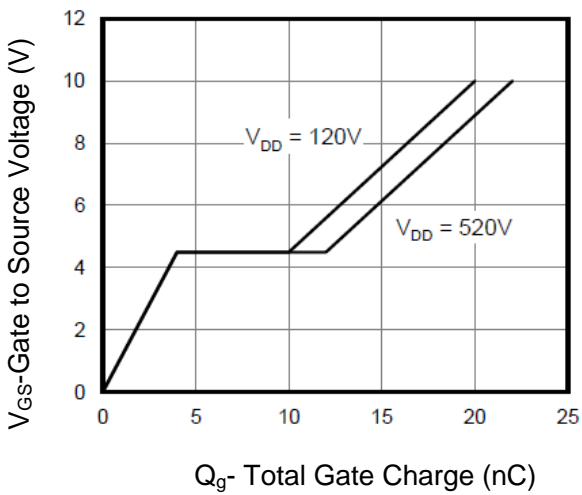

Figure 7. Gate Charge

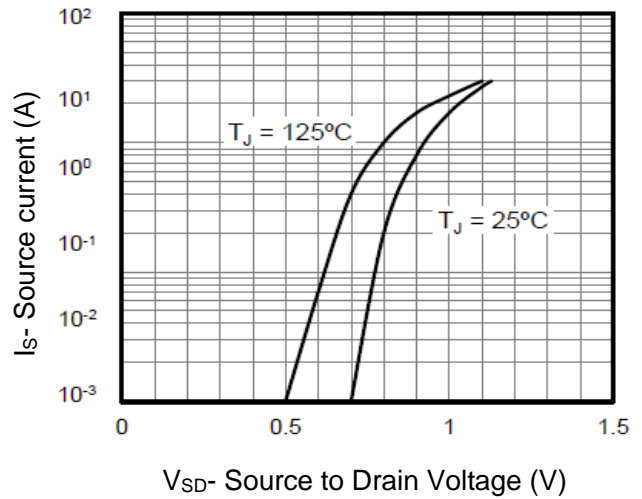

Figure 8. Body Diode Forward Voltage

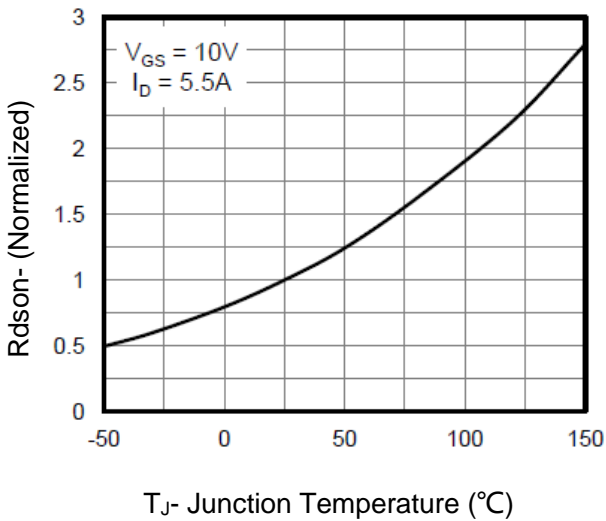

Figure 9. On-Resistance vs. Junction Temperature

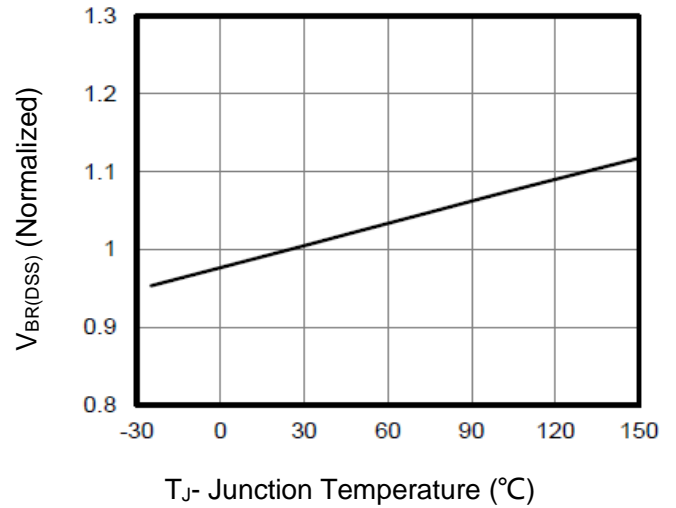

Figure 10. Breakdown Voltage vs. Junction Temperature

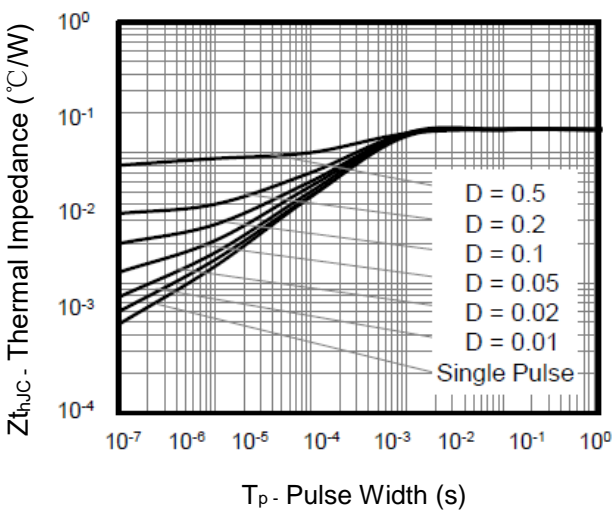

Figure 11. Transient Thermal Impedance (TO-251/TO-252/TO-220)

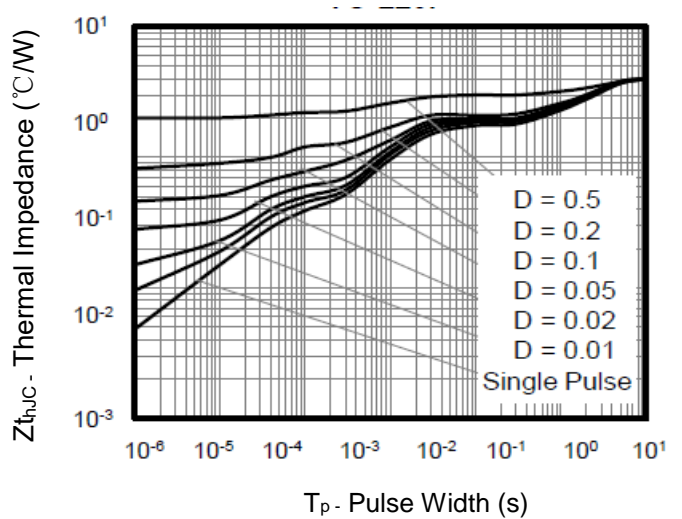
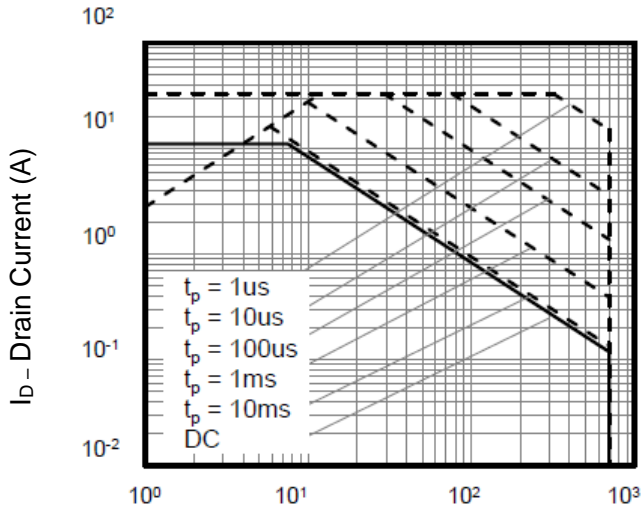
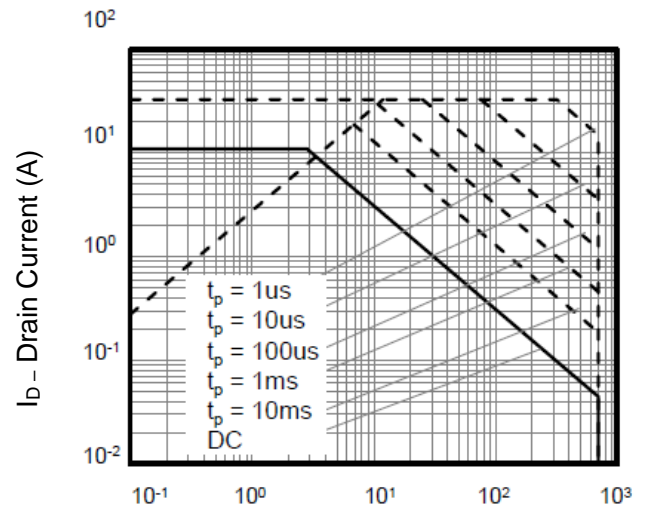

Figure 12. Transient Thermal Impedance (TO-220F)



$V_{DS}$  - Drain to Source voltage (V)

**Figure 13. Safe Operation Area for TO-251/TO-252/TO-220**



$V_{DS}$  - Drain to Source Voltage (V)

**Figure 14. Safe Operation Area for TO-220F**

TO-251 Package information

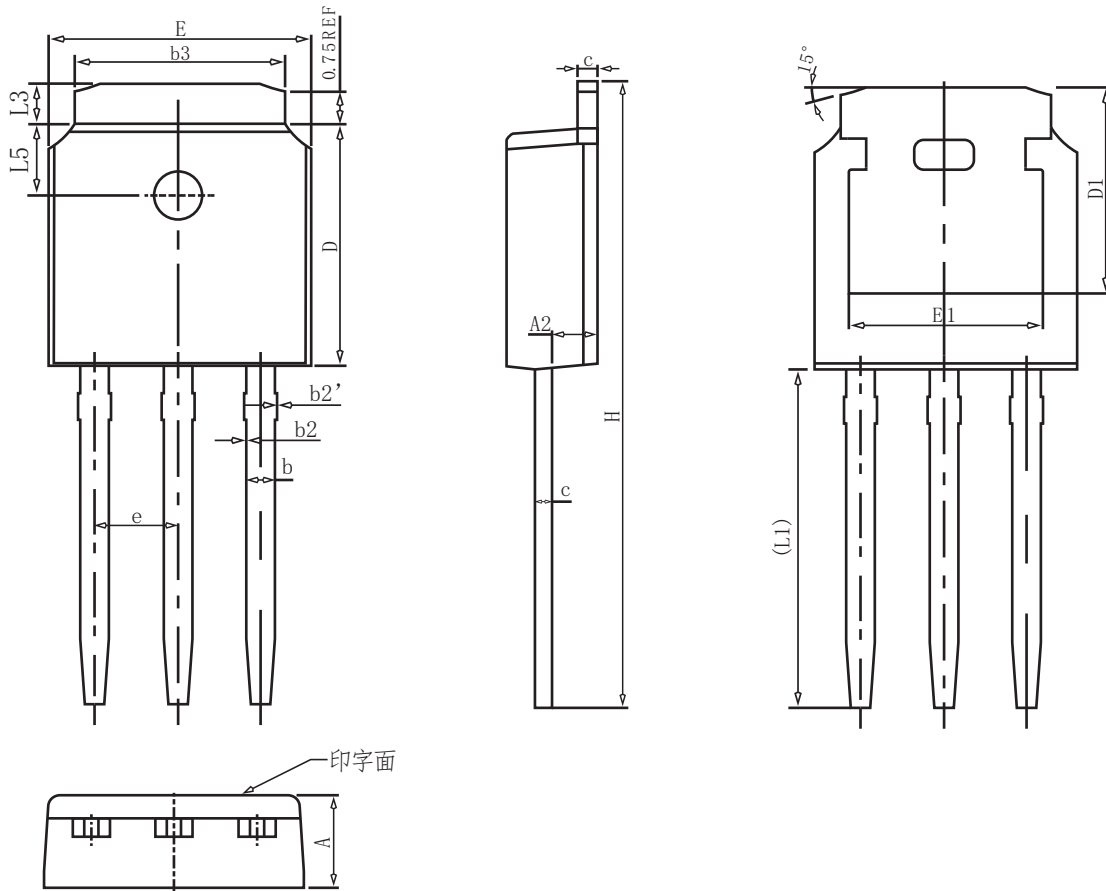

COMMON DIMENSIONS

SYMBOL	mm		
	MIN	NOM	MAX
A	2.20	2.30	2.40
A2	0.97	1.07	1.17
b	0.68	0.78	0.90
b2	0.00	0.04	0.10
b2'	0.00	0.04	0.10
b3	5.20	5.33	5.50
c	0.43	0.53	0.63
D	5.98	6.10	6.22
D1	5.30REF		
E	6.40	6.60	6.80
E1	4.63	-	-
e	2.286BSC		
H	16.22	16.52	16.82
L1	9.15	9.40	9.65
L3	0.88	1.02	1.28
L5	1.65	1.80	1.95

TO-252 Package information

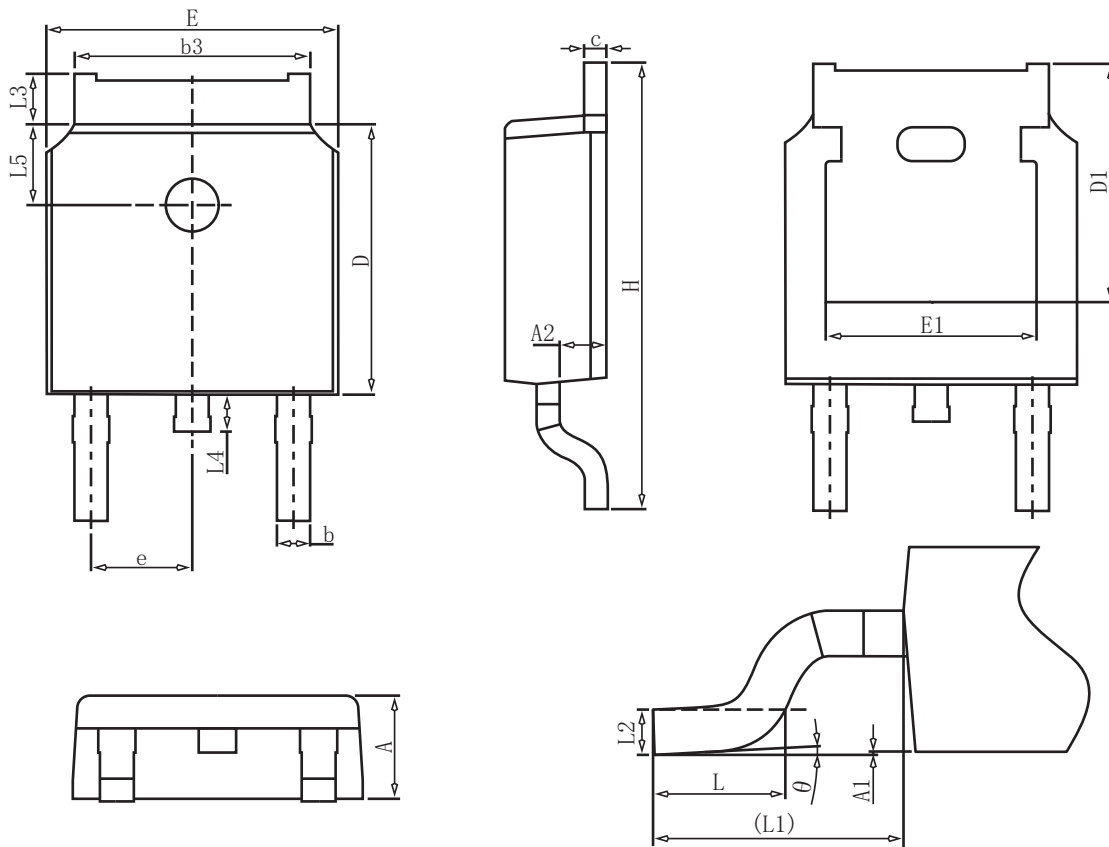

COMMON DIMENSIONS

SYMBOL	mm		
	MIN	NOM	MAX
A	2.20	2.30	2.40
A1	0.00	-	0.20
A2	0.97	1.07	1.17
b	0.68	0.78	0.90
b3	5.20	5.33	5.50
c	0.43	0.53	0.63
D	5.98	6.10	6.22
D1	5.30REF		
E	6.40	6.60	6.80
E1	4.63	-	-
e	2.286BSC		
H	9.40	10.10	10.50
L	1.38	1.50	1.75
L1	2.90REF		
L2	0.51BSC		
L3	0.88	-	1.28
L4	0.50	-	1.00
L5	1.65	1.80	1.95
θ	0°	-	8°

TO-220 Package information

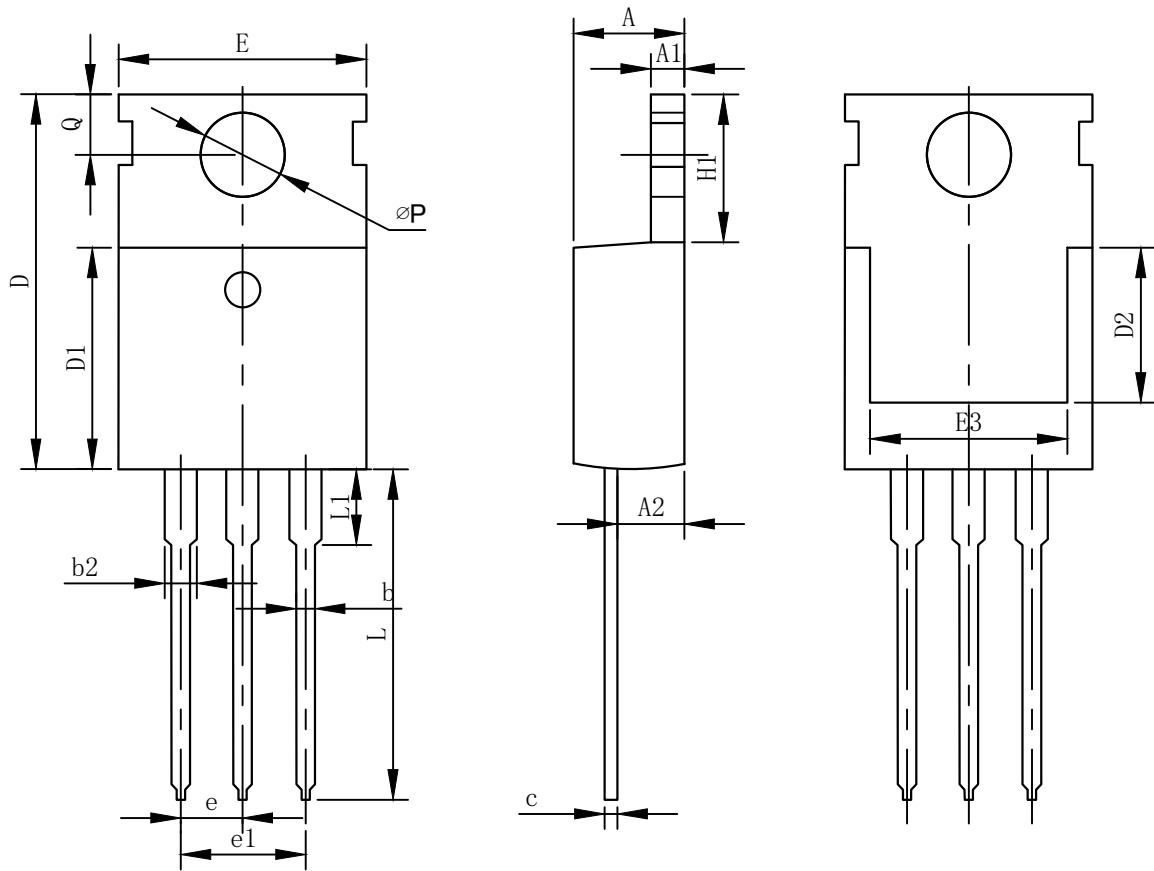

COMMON DIMENSIONS

SYMBOL	mm		
	MIN	NOM	MAX
A	4.37	4.57	4.70
A1	1.25	1.30	1.40
A2	2.20	2.40	2.60
b	0.70	0.80	0.95
b2	1.70	1.27	1.47
c	0.45	0.50	0.60
D	15.10	15.60	16.10
D1	8.80	9.10	9.40
D2	5.50	-	-
E	9.70	10.00	10.30
E3	7.00	-	-
e	2.54BSC		
e1	5.08BSC		
H1	6.25	6.50	6.85
L	12.75	13.50	13.80
L1	-	3.10	3.40
øP	3.40	3.60	3.80
Q	2.60	2.80	3.00



## TO-220F Package information

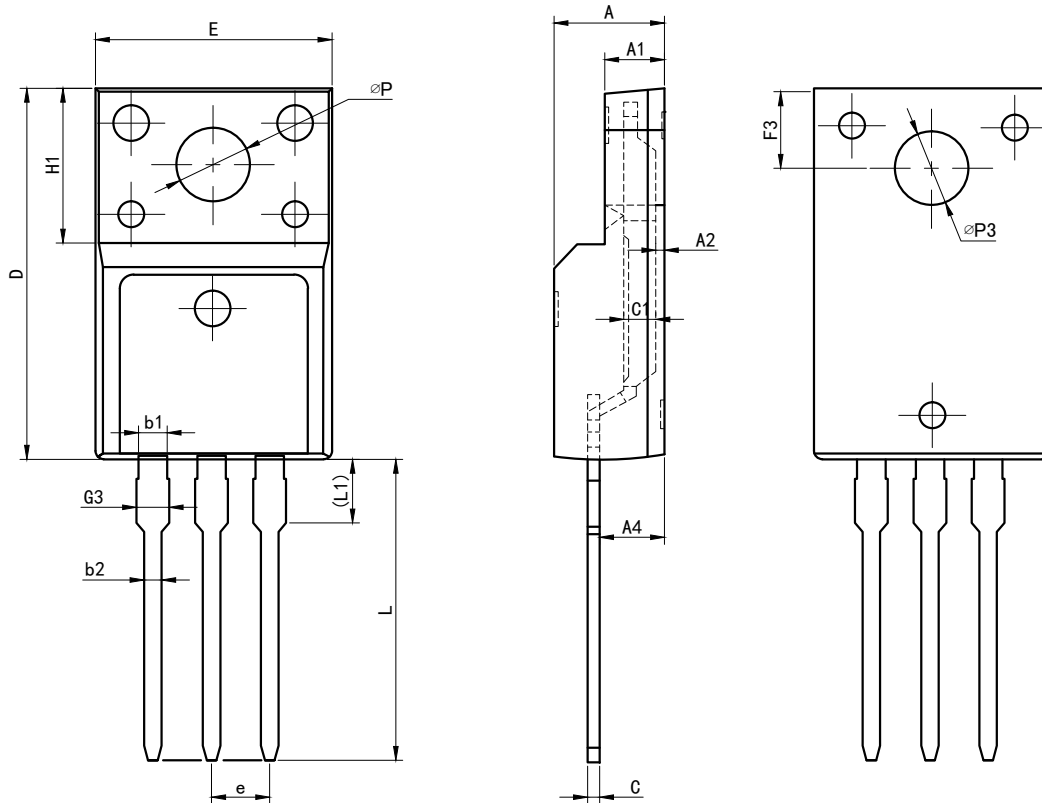

### COMMON DIMENSIONS

SYMBOL	mm		
	MIN	NOM	MAX
E	9.96	10.16	10.36
A	4.50	4.70	4.90
A1	2.34	2.54	2.74
A2	0.30	0.45	0.60
A4	2.56	2.76	2.96
c	0.40	0.50	0.65
c1	1.20	1.30	1.35
D	15.57	15.87	16.17
H1	6.70REF		
e	2.54BSC		
L	12.68	12.98	13.28
L1	2.93	3.03	3.13
φP	3.03	3.18	3.38
φP3	3.15	3.45	3.65
F3	3.15	3.30	3.45
G3	1.25	1.35	1.55
b1	1.18	1.28	1.43
b2	0.70	0.80	0.95